

Mickel 24th July 23

1 THE CRANBERRY TART J32 · 3/4L

Terry Glasspool: *Thirty Popular Dances, Volume Two* · Crib: *MiniCrib*s · Diagram: Keith Rose's Diagrams

- 1-8 1M sets & casts 1 place, sets & petronella turns between 3s facing up **while** 1L stands for 2 bars then sets, casts 1 place & sets
- 9-16 1M sets in line with 3s & all 3 Adv+Ret then 1M advances to partner **while** 1L petronella turns between 2s & sets in line with 2s then all 3 Adv+Ret, 1L pulling back RSh (bar 16) to face 2L
- 17-24 1L followed by partner dances tandem reel of 3 across with 2s (RSh to 2L) to end in 2nd place own sides
- 25-32 1s dance RSh reels of 3 on sides giving RSh to 3s. 2 1 3

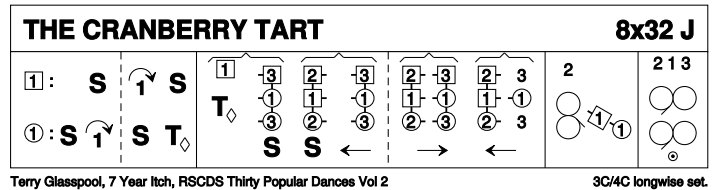

2 ABBOT HOUSE R80 · 4S

Amy Drysdale: *Dunfermline Branch 90th Anniversary Book* · Crib: *MiniCrib*s · Diagram: Keith Rose's Diagrams

- 1-8 All circle 8H round & back
- 9-16 Ladies dance 1/2 RH across, turn opp Man LH once round, Ladies dance 1/2 RH across **while** Men dance 1 place anticlockwise. All turn 'new partner' LH into square set
- 17-24 Men repeat bars 9-16, end turning original partner LH into square set. 2 3 4 1
- 25-32 All Adv+Ret, all turn (birl) corner LH
- 33-40 All set to partner & change places RH, change places LH with next person, & set to next facing person
- 41-48 All change places RH with facing person, change places LH with next person & all turn (birl) partner RH to end 4s (1st place) facing 1s (2nd place) & 3s (4th place) facing 2s (3rd place). 4 1 2 3
- 49-56 1s+4s & 2s+3s dance R&L
- 57-64 1s+4s & 2s+3s Adv+Ret, set & change places RH with dancer opposite to finish in square set. 1 4 3 2
- 65-72 All dance Set+Link with partner; 2s+4s promenade clockwise inside set to original places. 1 2 3 4
- 73-80 All circle 8H round & back. 1 2 3 4

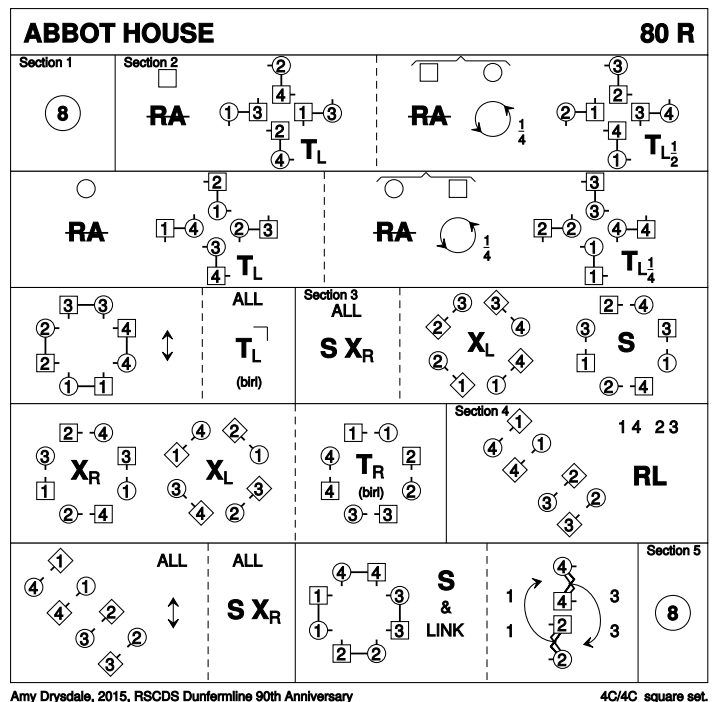

3 FLORIDA STREET "CAMBIO CAMBIO" S32 · 3/4L

Jim Stott: The Argentine Collection 2020 · Crib: MiniCribs · Diagram: Keith Rose's Diagrams

- 1-4 1L+2M dance towards each other (1 step), pull back RSh & cast **while** 1M & 2L dance towards each other (1 step), pass LSh & dance out to sides. 2 1 3
- 5-8 2s+1s circle 4H round to left
- 9-16 2s+1s+3s 1/2 turn partner RH, pull back RSh & dance out to opp sides; 2s+1s+3s circle 1/2 round to left. Finish 3s at top in centre NHJ, 1s in 2nd place own side, 2s in centre at bottom NHJ
- 17-24 2s+3s dance 1/2 R&L then Set+Link **while** 1s set, dance DoSiDo & set. 2 1 3
- 25-32 2s+1s+3s dance Grand Chain (2s cross, 1s+3s change places RH on sides to start)

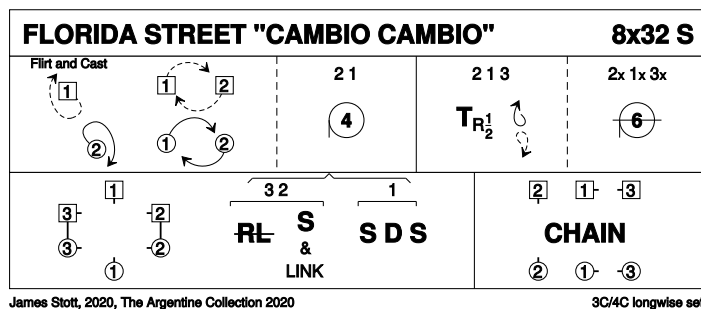

4 INCHMICKERY J32 · 5/5L

Roy Goldring: 14 Social Dances for 2000 · Crib: MiniCribs · Diagram: Keith Rose's Diagrams

- 1-8 1s+2s circle 4H round to left, 1s dance in & cast to 3rd place
- 9-16 1s dance RH across (1L with 3s & 1M with 4s), pass RSh & dance LH across with other couple 2 3 1 4 5
- 17-24 1L+2M (at top) also 1M+5L (at bottom) turn RH, 1s pass RSh & 1L+5M (at bottom) also 1M+2L (at top) turn LH (1s end 3rd place own side)
- 25-32 1s dance in & cast to 5th place, 5s+1s circle 4H round to right. 2 3 4 5 1

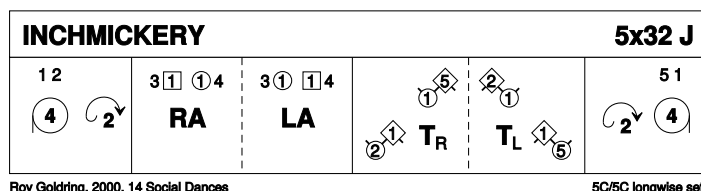

5 CLUTHA R48 · 4S

RSCDS XXXI 2 · Crib: MiniCribs · Diagram: Keith Rose's Diagrams

- 1-8 1L+3M turn RH, dance round partner RSh to turn each other again RH ending in middle holding RH & partners LH
- 9-16 1s+3s Bal-in-Line, 1L+3M turn partners LH into the middle & Bal-in-Line again, turn partner LH to original pstns
- 17-24 1s+3s dance R&L
- 25-32 1s+3s dance Ladies' Chain
- 33-40 All turn corners RH retaining hold & hold partners LH to form a circle (men facing out), all set & turn partner LH (4 bars) into prom hold
- 41-48 All dance round anticlockwise in prom hold to original pstns
Repeat with 2L+4M, 3L+1M, 4L+2M

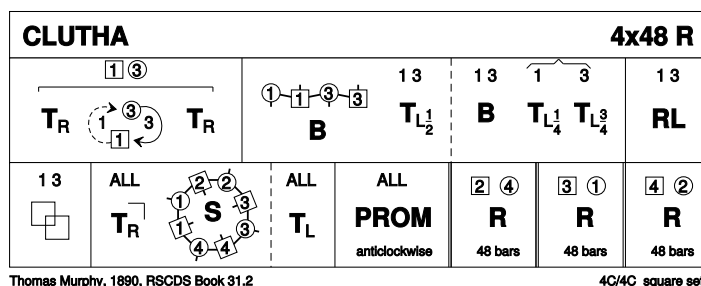

6 ADIEU MON AMI S32 · 3/4L

RSCDS XXIV 11 · Crib: MiniCribbs · Diagram: Keith Rose's Diagrams

- 1-8 1s+2s set on sides, turn 2H, set to partners & turn 2H into Allemande hold
- 9-16 1s+2s Allemande 1s end facing 1st corners
- 17-24 1s dance 'Hello-Goodbye' setting, into middle facing partner, clap & petronella turn to 2nd place
- 25-32 2s+1s+3s circle 6H round & back

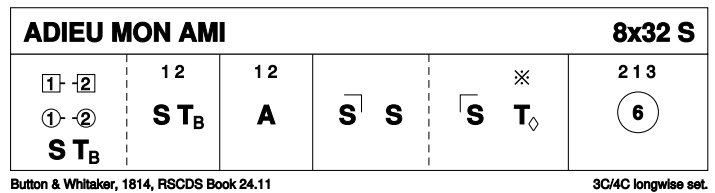

7 A HOT TODDY J32 · 3/4L

William Adams: Glasgow Diamond Jubilee · Crib: MiniCribbs · Diagram: Keith Rose's Diagrams

- 1-8 1s cross RH & cast down 1 place, 1s dance 1/2 RSh reels of 3 across (1L with 2s & 1M with 3s)
- 9-16 1s cross RH & cast right (1M down 1L up), 1s dance into centre & turn about to BtoB with partner & set **while** 2s+3s set & dance in, retire & set
- 17-24 1s dance RH across (1L with 2s & 1M with 3s) 1s ending 2nd place own sides, 1s dance 1/2 reel of 3 across (1M with 2s & 1L with 3s)
- 25-32 1s cross RH & 2s+1s+3s set, all turn partners RH

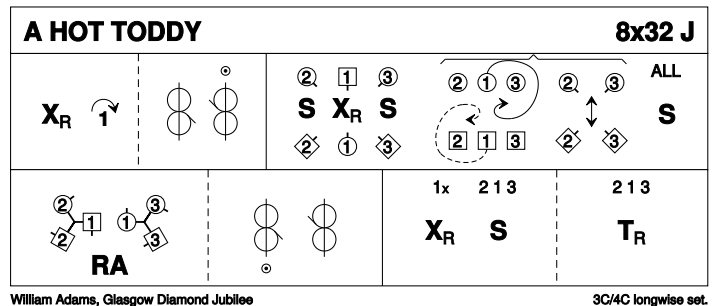

8 RYE TWIST R32 · 5/5L

Sue McKinnell: RSCDS XLVIII 5 · Crib: MiniCribbs · Diagram: Keith Rose's Diagrams

- 1-4 1M+2s dance 1/2 reel of 3 across (1M+2L pass LSh). 1M finishes between 2s facing down
- 5-8 1M+3s dance 1/2 reel of 3 across (1M+3M pass RSh), 1M finishes between 3s facing down **while** 1L+2s dance 1/2 reel of 3 across (1L+2L pass RSh). 2L finishes between 2s facing down. 2s finish in 1st place
- 9-12 1M+4s, 1L+3s repeat bars 5-8 (1M+4L, 1L+3M pass LSh). 3s finish in 2nd place
- 13-16 1M+5s, 1L+4s repeat bars 5-8 (1M+5M, 1L+4L pass RSh). 4s finish in 3rd place
- 17-20 1M dances out of end, casts round 5L place, crossing to 4M place **while** 1L+5s dance 1/2 reel of 3 across (1L+5M pass LSh). 1L finishes in 4L place, 5s in 5th place
- 21-24 1s+5s dance 1/2 LH across, cross LH with partner
- 25-32 All couples set, cross RH with partners, all set, cross RH with partners 2 3 4 5 1

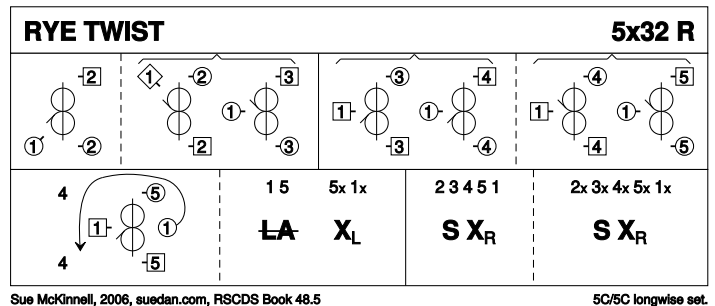

9 CITY OF BELFAST S32 · 3/3L

Lucy Mulholland: RSCDS XLVIII 6 · Crib: MiniCribs · Diagram: Keith Rose's Diagrams

1-8 1s dance 1/2 Fig of 8 round 2s, 1L+2M turn RH 1.1/4 times **while** 1M+2L turn LH 1.1/4 times & 1s end BtoB facing opp sides

9-16 1s+2s dance reel of 4 across in 2nd place. 2s end in 1st places **while** 1s pass LSh to face 1st corners

17-24 1s set to 1st corner & 2nd corner ending (turning to right) between corners, all set & 1s cross RH

25-32 1s+3s dance Espagnole:

25-26 1s+3s cross (Ladies lead across RH passing between Men) with Ladies changing places RH

27-28 1s+3s cross back (Men lead across RH between Ladies) with Men changing places RH

29-32 3s turn RH as 1s turn LH to end 2 3 1

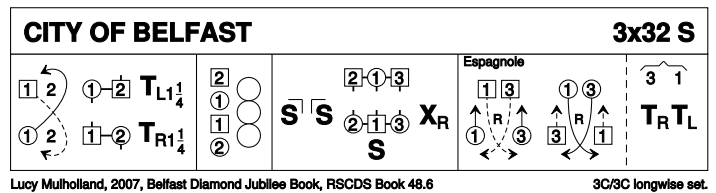

10 POSTIE'S JIG J32 · 4/4L

Roy Clowes: Thirty Popular Dances, Volume Two · Crib: MiniCribs · Diagram: Keith Rose's Diagrams

1-8 1s & 4s set & cast in 1 place, 1s & 4s dance 1/2 Figs of 8 round new end couples

9-12 1M+4M & 1L+4L cross (men making an arch) & turn corners with free hand to face up/down

13-16 1s+4s dance down/up (couple dancing up make the arch) & turn corners

17-24 Repeat bars 9-16 from new positions

25-32 1s+4s dance 1/2 R&L, turn partner RH

