

Mickel 14th August 23

1 LIQUID ASSETS J32 · 3/4L

John Drewry: *New Dances* by John Drewry 2003 · Crib: *MiniCribs* · Diagram: *Keith Rose's Diagrams*

- 1-8 1s cross down to dance reflection reels of 3 on opposite sides 1s ending at top on opposite sides facing in & 2s face out
- 9-16 1s turn 2s 1.1/2 times with nearer hands, 1s turn 3s 1.1/2 times with other hand
- 17-24 1s cross up to dance reels of 3 on own side At end 3s face out
- 25-32 1s turn 3s 1.1/2 times with nearer hands, 1s dance up to top & cast to 2nd places

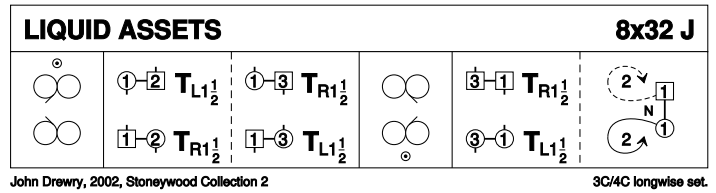

2 OOMPAH, OOMPAH, SHOVE IT UP YOUR JOOMPAH! R32 · 2/3L

John Drewry: *The Stoneywood Collection* · Crib: *MiniCribs* · Diagram: *Keith Rose's Diagrams*

- 1-8 1s dance down 1 place & cast on own side back to places, 1s+2s turn 1.1/4 times on sides (Men RH & Ladies LH) to end in line of 4 facing down
- 9-16 1s+2s in line of 4 dance down for 4 bars & 1s swing 2s into face partners, 1s+2s slip step up to top
- 17-24 1s+2s dance Poussette
- 25-32 2s dance down between 1s & cast back to top places, 1s dance up between 2s & cast back to 2nd place

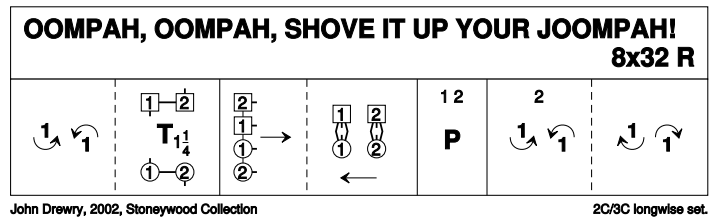

3 THE ATHENAEUM S32 · 3/3L

Alasdair Brown: Glasgow Branch 100th Anniversary Dances · Crib: MiniCribs · Diagram: Keith Rose's Diagrams

- 1-8 1s dance down the middle (4 steps), dance up (2 steps) & cast up behind 2s into top place
- 9-16 1s+2s dance Rose Progression:
 - 9-10 1M+2L set as 1L+2M change places RH
 - 11-12 1M+2L 1/2 turn 2H to face each other as 2M & 1L dance into partner's place
 - 13-14 2L+1M cast into each other's place as 1L+2M 1/2 turn 2H to face each other
 - 15-16 2L & 1M dance into 1st/2nd places own sides as 2M & 1L cast to right
- 17-24 All circle 6H round & back
- 25-32 2s+1s+3s Set & Rotate for 3 couples:

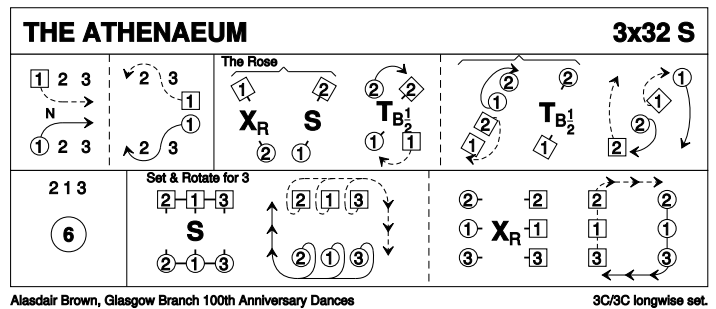

Set & rotate singly & chase clockwise to form lines of 3 across (Men facing down & Ladies up) all change places RH with partner & chase clockwise to own sides. 3 1 2

4 DRAGONFLY J32 · 3/4L

Bob McMurtry: Dragonfly · Crib: MiniCribs · Diagram: Keith Rose's Diagrams

- 1-8 2s followed by 1s dance down for 3 bars, dance back up (3 bars), then 1s cast to 2nd place
- 9-16 1s set & dance La Baratte:
 - 11-12 1s 1/2 turn RH & retain hand but at arm's length from each other
 - 13-14 1M retraces steps with 1L turning right under Man's arm briefly into Allemande hold (Man behind Lady facing Ladies original place) & releasing Ladies RH she turns under Mans left arm until almost in original places
 - 15-16 1s turn 3/4 LH (1M faces 2M, 1L faces 3L)
- 17-24 1s dance reels of 3 across (1M LSh to 2M, 1L LSh to 3L) ending with RH turn to face same couples
- 25-32 1s dance reels of 3 across (1M RSh to 2L, 1L RSh to 3M) ending in 2nd places

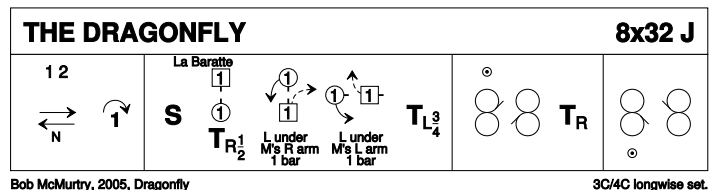

5 TOAST TO THE MOUSIES R32 · 3/4L

Sara Gratiot: RSCDS LIII 13 · Crib: MiniCribs · Diagram: Keith Rose's Diagrams

- 1-8** 1s dance in & cast 1 place (2s step up), dance down between 3s & cast up to 2nd place
- 9-16** 2s+1L also 1M+3s dance RH across & 1s pass RSh to dance LH across with other couple, 1s end back to back in the middle (1M facing up, 1L down) facing 2s/3s (2s facing down, 3s up NHJ)
- 17-20** All set, 2s & 3s make arches, dance down/up to meet as 1s dance under arches. Finish 1M in 1st place, 1L in 3rd place (facing down/up) & 2s & 3s back to back in middle NHJ (2s facing up, 3s down).
- 21-24** All set, 2s & 3s making arches dance to ends & cast into reel **while** 1s dance under arch passing LSh and finish between end couple facing 1st cnr
- 25-32** 2s+1L also 1M+3s dance LSh reels across (2s+3s make loops into the reel) to end 2 1 3. All set

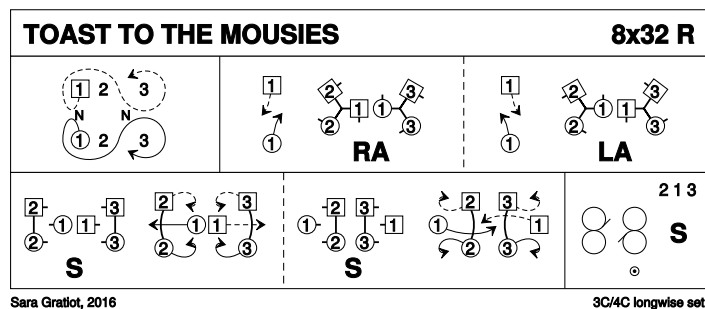

Note: after 2nd time through 1s may repeat bars 1-4 to get to 4th place

6 THE SWAN AND THE TAY S32 · 3/3L

Audrey Saunders: Scottish Country Dances for Perth 800 · Crib: MiniCribs · Diagram: Keith Rose's Diagrams

- 1-8** 1s dance Figs 8 own sides dancing in & down to start (giving hands where possible)
- 9-16** 1s cross down to dance reels of 3 on opp sides (joining hands where possible) & 1s end facing 1st corners, 2s end in 1st place
- 17-20** 1s dance Corners Pass+Turn with 1st corners (corners turn RH), pass RSh on bar 20 to face 2nd cnrs
- 21-24** 1s dance Corners Pass+Turn with 2nd corners (corners turn RH). Pass RSh on bar 24 to end 2nd place own sides
- 25-32** All set, all cross RH, all chase clockwise 1/2 way round to own sides 3 1 2

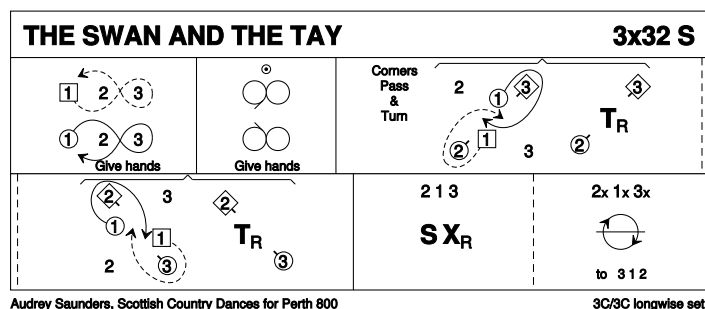

7 CHASED LOVERS J32 · 3/4L

Tim Wilson: RSCDS LIII 9 · Crib: MiniCribs · Diagram: Keith Rose's Diagrams

- 1-4** 1s set, cross down (no hands) to 2nd place facing out (2s step up 3-4)
- 5-8** 1s cast down behind 3s, meet & dance up centre with 1L leading, 1M following, to face 2M (her 1st corner)
- 9-16** 1s, in tandem, dance LSh reel of 3 on 1st corner diagonal (out of top of set to start), finishing by 1s pulling back RSh to face down, 1M leading, facing 3M
- 17-24** 1s, in tandem, dance RSh reel of 3 on 2nd corner diagonal (out bottom of set to start), finishing with 1s facing own 1st corners
- 25-32** 1s dance Pass+Turn with 1st corners, (pass RSh), Pass+Turn with 2nd corners, finishing passing RSh to 2nd place own sides

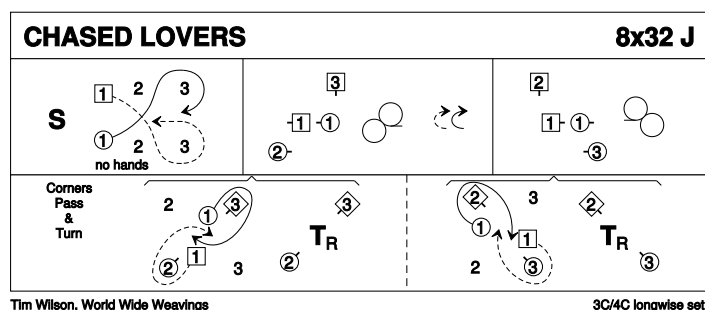

8 ABBOT HOUSE R80 · 4S

Amy Drysdale: Dunfermline Branch 90th Anniversary Book · Crib: MiniCribbs · Diagram: Keith Rose's Diagrams

- 1-8** All circle 8H round & back
9-16 Ladies dance 1/2 RH across, turn opp Man LH once round, Ladies dance 1/2 RH across **while** Men dance 1 place anticlockwise. All turn 'new partner' LH into square set
17-24 Men repeat bars 9-16, end turning original partner LH into square set. 2 3 4 1
25-32 All Adv+Ret, all turn (birl) corner LH
33-40 All set to partner & change places RH, change places LH with next person, & set to next facing person
41-48 All change places RH with facing person, change places LH with next person & all turn (birl) partner RH to end 4s (1st place) facing 1s (2nd place) & 3s (4th place) facing 2s (3rd place). 4 1 2 3
49-56 1s+4s & 2s+3s dance R&L
57-64 1s+4s & 2s+3s Adv+Ret, set & change places RH with dancer opposite to finish in square set. 1 4 3 2
65-72 All dance Set+Link with partner; 2s+4s promenade clockwise inside set to original places. 1 2 3 4
73-80 All circle 8H round & back. 1 2 3 4

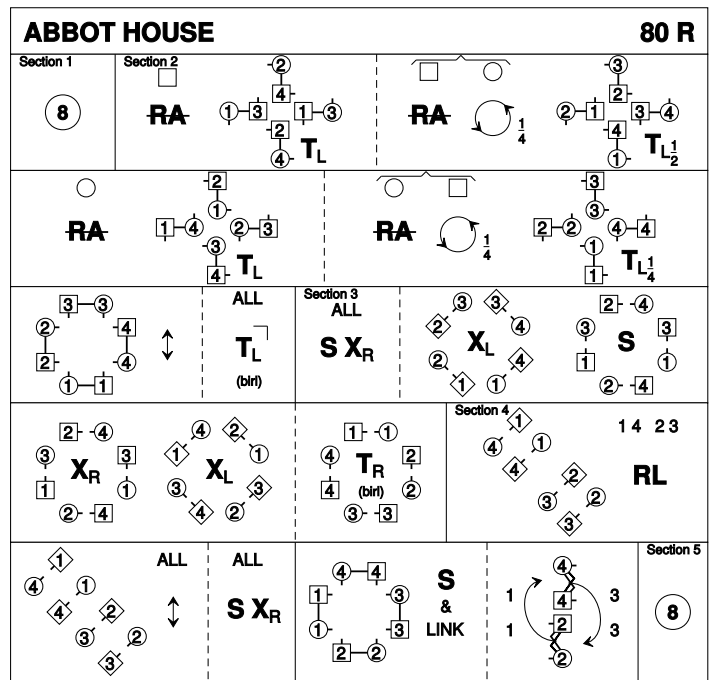

Amy Drysdale, 2015, RSCDS Dunfermline 90th Anniversary

4C/4C square set.

9 GOLD IN TASSIE S32 · 4/4L

John Drewry: Australian Book · Crib: MiniCribbs · Diagram: Keith Rose's Diagrams

- 1-8** 1s+2s+3s set, cross RH, set & 1/2 turn LH into prom hold facing up
9-16 1s+2s+3s Promenade & 1s end casting to 3rd place
17-24 2s+1s dance double Fig of 8 round 3s (1s cross up to start)
25-32 1s & 4s set, turn 2H, 1s followed by 4s dance up between 3s & cast down (1s to 4th place & 4s to 3rd place)

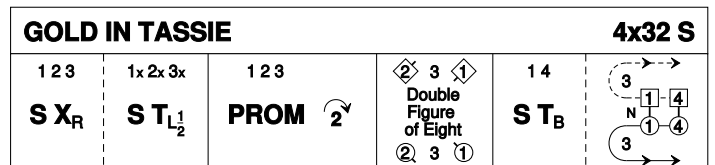

John Drewry, 1995, Australian Book

4C/4C longwise set.

10 COLIN'S KILTS J40 · 3/4L

Margaret Young: A Book of Perth Dances · Crib: MiniCribbs · Diagram: Keith Rose's Diagrams

- 1-8** 1s+3s dance RH across 1/2 way, 1/2 turn partners RH & 1M leads his partner up behind 2M to end in 1st places (opposite sides) **while** 3L leads her partner down behind 2L to end in 3rd place opposite sides
- 9-16** 1s+3s repeat (from opposite sides) ending in original places
- 17-24** 1s+2s+3s dance RSh reels of 3 (6 bars) & 1s+2s change places RH on sides
- 25-32** 2s+1s+3s set twice & turn partners RH
- 33-40** 2s+1s+3s circle 6H round to left for 6 steps, pivot left & chase back to places. 2 1 3

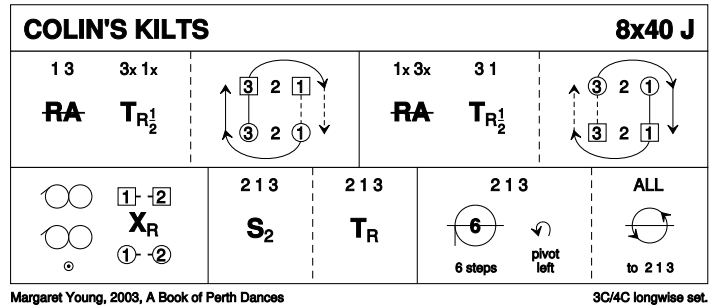

11 BALDYQUASH R32 · 3/4L

John Drewry: The Stoneywood Collection · Crib: MiniCribbs · Diagram: Keith Rose's Diagrams

- 1-8** 1s cross down to dance reflection reels on opposite sides
- 9-16** 1s cross RH to own sides, cast 1 place, 1M dances up between 2s & casts to 2nd pl opp side **while** 1L dances down between 3s & casts to 2nd pl
- 17-24** 1s turn RH (4 bars), cast round 1st corners to 2nd place own sides
- 25-32** 2s+1s+3s circle 6H round & back

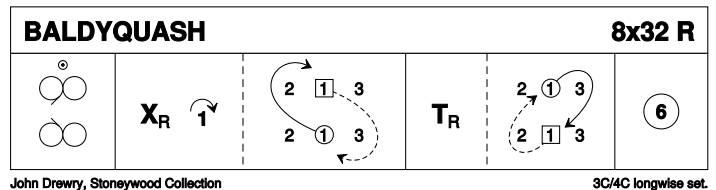

12 SPARE

13 ONE FOR THE ROAD R32 · 3/4L

Pam Perkins: New Forest Scottish Country Dances · Crib: MiniCribbs

- 1-8** 1s set, cast 1 place & dance 1/2 Fig of 8 around 2s
- 9-16** 2s+1s+3s Adv+Ret 2 steps & turn partner RH
- 17-24** 1s cross down between 3s, cast up to 2nd place, lead up & cast to 2nd place own side
- 25-32** 2s+1s+3s circle 6H round & back